

COURSALIS 1000 (509610000M001B)

GENERAL DATA



HIGH PERFORMANCE AIR CURTAIN FOR TERTIARY

Exclusive arch design, light and superfine
 High performance and low sound level
 Metallic housing with paint finish in white colour
 230V 50Hz motor

Impeller made of plastic (AS+fiberglass)
 Includes external control by remote control
 Designed for horizontal mural installation
 Easy adjustable air direction
 With operating indicator LED (ambient, air velocity and stop motion)
 Mounting brackets on wall
 Reach up to 3m.
 The indicated weight does not include the packaging (± 2Kg.)

APPLICATION

- Tertiary sector:
- Airports.
 - Schools
 - Malls.
 - Stores.
 - Supermarkets.
 - Train stations.
 - Hotels.
 - Restaurants
 - Pubs
 - Offices.
 - Banks
 - Gas stations
 - Logistics centers.
 - Industries, food industries.
 - Hospitals, clinics, health centers.
 - Veterinary clinics.
 - Refrigerated warehouses.

TECHNICAL DATA

Fan							
RPM	1400	Approx. weight	15.6 kg	Max. Flow	1600 m³/h		
Motor							
Power	0,165 kW	RPM	1400	I max. (230V)	0,75 A	Approx. weight	0 kg

DIMENSIONS

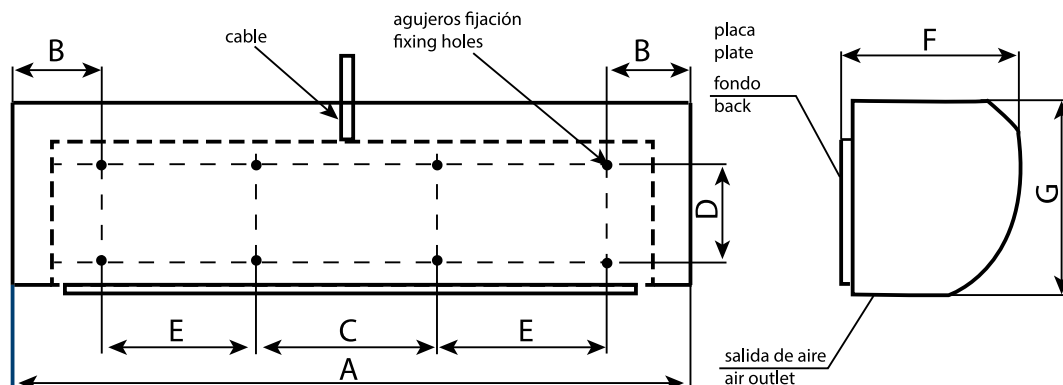

Dimensions (mm)

A	1150	F	195	G	220
---	------	---	-----	---	-----

WIRING DIAGRAM

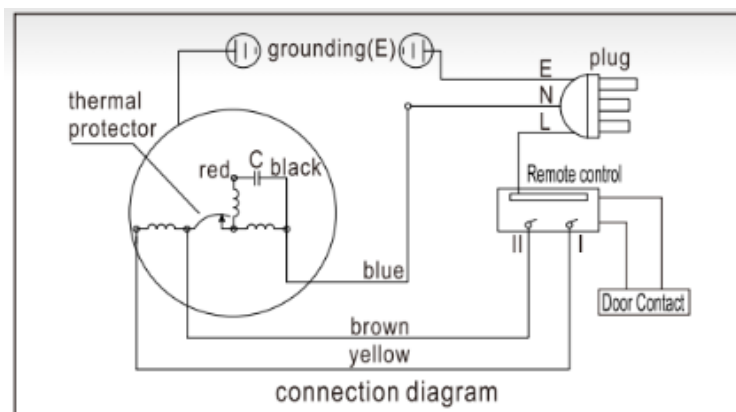

ACCESSORIES



SAFETY SWITCH
INT 25 3P A
REF: INT253PA



MAGNETIC CONTACT DOOR SWITCH FOR COURSALIS
MDS Coursalis
REF: 301034300

